



DGC-200 DIGITAL GENSET CONTROLLER

Basler Electric's Digital Genset Controller (DGC-200) is a highly advanced integrated genset control system. The DGC-200 is perfectly focused, combining rugged construction and microprocessor technology to offer a product that will hold up to almost any environment and flexible enough to meet your application's needs. This device provides genset control, transfer switch control, metering, protection and programmable logic in a simple, easy to use, reliable, rugged, and cost effective package.

Program the DGC-200 with easy to use front panel navigation keys and the large LCD display or with our enhanced BESTCOMSPPlus PC software. Either way, the easy to follow menus make setup and configuration fast and simple. Within BESTCOMSPPlus, we have provided a very powerful user-friendly programmable logic program that allows the user to meet specifications that previously would have required an additional PLC to meet. BESTCOMSPPlus is included at no additional cost and provides for remote communications, file transfer, and file management. It is one of the most intuitive software programs available for genset controllers.

FEATURES

- Generator Metering
- Generator Sequencing (via LSM-2020 Load Sharing Module)
- Engine Metering
- Genset Control
- Engine Protection
- Generator Protection 27(2), 32, 40Q, 51(2), 59(2), 81O, 81U
- Enhanced Generator Protection 51 and 47 available (optional)
- Load Sharing (via LSM-2020 Load Sharing Module)
- BESTCOMSPPlus (included with every DGC-200 at no additional cost)
 - Programming and setup software
 - Intuitive and powerful
 - Remote control and monitoring
 - Programmable Logic
 - USB communications
- Automatic Transfer Switch Control
- Exercise Timer
- Automatic Synchronizer (optional)
- Suitable for use on rental gensets with
 - Hi/Lo line sensing
 - Single or three phase sensing override
- SAE J1939 Engine ECU communications
- Automatic Generator Configuration Detection
- Selection of integrating reset or instantaneous reset characteristics for overcurrent protection
- Multilingual capability
- Remote communications to our RDP-110 Remote Annunciator
- Extremely rugged, fully encapsulated design
- 16 programmable contact inputs
- 7 Contact outputs: (3) 30 Adc and (4) Programmable 2 Adc rated contacts
- Additional (8) Programmable 2 Adc contacts (optional)
- Wide Ambient Temperature range
- Remote Dial-out and Dial-in capability with Internal Modem (optional)
- Modbus Communications with RS-485 (optional)
- Ethernet communications (via LSM-2020 Load Sharing Module)
- Expandable I/O capability via J1939 CANBUS (optional)
- UL recognized, CSA certified, CE approved
- HALT (Highly Accelerated Life Tests) tested
- IP 54 Front Panel rating with integrated gasket
- NFPA110 Level Compatible
- **Expandable functionality via add-on modules**
 - LSM-2020 Load Sharing Module
 - CEM-2020 Contact Expansion Module
 - AEM-2020 Analog Expansion Module

ADDITIONAL INFORMATION

INSTRUCTION MANUAL

Request Publication 9400200990



ROUTE 143, BOX 269 HIGHLAND, ILLINOIS 62249, U.S.A. PHONE 618-654-2341 FAX 618-654-2351

**DESCRIPTION,
FUNCTIONS and
SPECIFICATIONS**
pages 2 through 5

**FRONT PANEL DISPLAY
and
DIMENSIONS**
pages 5 and 6

**INTERCONNECT
DRAWING**
page 7

**ORDERING
INFORMATION**
page 8

**ENHANCEMENT
ACCESSORIES**
pages 9 through 12

DESCRIPTION

The DGC-2020 is a microprocessor based generator set controller that incorporates advanced technology and features into a value added, user friendly, rugged design. This device is encapsulated and is the most rugged genset controller found anywhere. It provides front panel and PC programmability. It can sense engine parameters directly via analog senders, or it can communicate with the engine's ECU using SAE J1939 CANBUS communications. This device offers programmable inputs and outputs and programmable logic to allow the user to easily customize the operation of the DGC-2020 as desired. The DGC-2020 also has automatic transfer switch control (mains failure).

The DGC-2020 can be configured by a customer selected style number. This allows the user to only purchase what is needed, adding to the value of the DGC-2020 controller. The DGC-2020 can be configured to have eight additional output contacts, an internal RS-485, an internal industrial modem for remote communications and dialing out to a pager when the DGC-2020 detects trouble. The DGC-2020 also has optional features for enhanced generator protection, and an integrated automatic synchronizer.

FUNCTIONS

GENSET PROTECTION

Generator (Standard Protection)

Undervoltage (27) Overvoltage (59)
Reverse Power (32) Overfrequency (81O)
Loss of Excitation (40Q) Underfrequency (81U)

Enhanced Generator Protection (Optional)

Phase Imbalance (47)
Generator Overcurrent (51)

All Generator Protection features are programmable as Alarms or Pre-alarms.

Engine

Alarms (Shutdowns)

Low Oil Pressure
High Coolant Temperature
Low Coolant Level
Overspeed
Overcrank
Engine Sender Unit Failure
Fuel Leak/Fuel Sender Failure
Emergency Stop
Battery Charger Failure

Pre-Alarms (Warnings)

Low Oil Pressure Engine kW Overload (3)
High Coolant Temperature Maintenance Interval Timer
Low Coolant Temperature Low Coolant Level
Battery Overvoltage High Fuel Level
Weak Battery Low Fuel Level
Battery Charger Failure Fuel Leak Detect
Engine Sender Unit Failure

All Alarms and Pre-Alarms can be enabled or disabled via the BESTCOMSPPlus PC software or the front panel.

GENSET METERING

- Metered generator parameters include voltage, current, Hz, real power (watts), apparent power (VA), and power factor.
- Metered engine parameters include oil pressure, coolant temperature, RPM, battery voltage, fuel level, engine runtime, and various J1939 supported parameters.

ENGINE CONTROL

Cranking Control: Cycle or Continuous (Fully Programmable)

Engine Cooldown: Smart Cooldown function saves fuel and engine life.

Successful Start Counter: Counts and records successful engine starts

Timers:

- Engine Cooldown Timer
- Engine Maintenance Timer
- Pre-Alarm Time Delays for Weak/Low Battery Voltage
- Alarm Time Delay for Overspeed
- Alarm Time Delay for Sender Failure
- Arming Time Delays after Crank Disconnect:
 - Low Oil Pressure
 - High Coolant Temperature
- Pre-Crank Delay
- Continuous or Cycle Cranking Time Delay

EVENT RECORDING

The DGC has an event recorder that provides a record of alarms, pre-alarms, engine starts, engine runtime loaded, engine runtime unloaded, last run date, and many other events that are all date and time stamped to help the user determine the cause and effect of issues related to the generator set.

TRANSFER SWITCH CONTROL (MAINS FAILURE)

The DGC-2020 monitors utility (mains) and determines if it is providing power that is suitable for the loads. If the utility (mains) goes beyond predetermined levels, the generator is started and the utility (mains) is disconnected from the load and the generator is connected. When the utility (mains) returns to acceptable levels for a sufficient time, the generator is disconnected and the utility (mains) is reconnected to the load. It also includes appropriate settings timers for establishing stable utility (mains) operation.

FUNCTIONS, continued

PROGRAMMABLE LOGIC

The DGC-2020 offers a very powerful, yet easy to use, programmable logic scheme for custom programming of the various inputs, outputs, alarms, and pre-alarms. It allows these elements to be integrated into a complete logic scheme so that the user can meet even the most complex specification. The Programmable Logic control includes the selection of logic gates and timers with drag-and-drop technology to make it fast and simple.

REMOTE DISPLAY PANEL ANNUNCIATION

The DGC-2020 can communicate to a remote display panel, Basler Model RDP-110. This requires only two wires to annunciate all of the alarms and pre-alarms required by NFPA-110 Level I and II.

MODEM (Optional)

A dial-out modem enables remote control, monitoring, and setting of the DGC-2020. When an alarm or pre-alarm condition occurs, the DGC-2020 can dial up to four telephone numbers, in sequence, until an answer is received and the condition is annunciated.

RS-485 (Modbus) (Optional)

An optional RS-485 communication port uses Modbus communication protocol and enables remote control and monitoring of the DGC-2020 over a polled network.

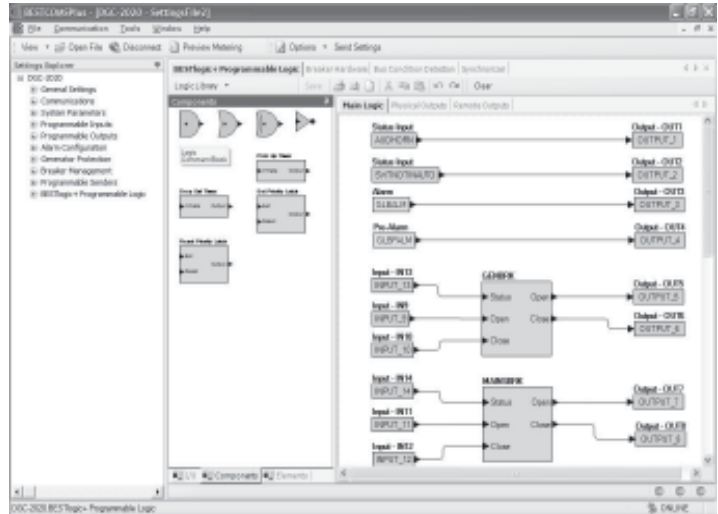

J1939 COMMUNICATIONS

J1939 CANBUS communications allows the DGC to communicate to the engine's ECU (Engine Control Unit) to gather critical engine information like oil pressure, engine coolant temperature, RPM, battery voltage, and many more. By utilizing the ECU, adding analog engine senders is no longer required. This can save substantial money for the installer. It also eliminates any errors or discrepancies between the ECU data and the data displayed on the DGC that may be present due to analog sender inaccuracies or incompatibility. A total of 47 engine parameters can be obtained via the ECU. You also can derive the added benefit of having access to the ECU's diagnostic troubleshooting codes, or DTCs. The DTCs provide information about the engine's operating conditions and communicates these via J1939, to the DGC, thus eliminating the need for hand-held service tools to diagnose simple engine issues. With the optional modem, the DTCs can be accessed remotely, and valuable service time can be saved by remote diagnostics and taking the right parts to fix the problem the first time.

SPECIFICATIONS

Operating Power

Nominal: 12 or 24 Vdc

Range: 6 to 32 Vdc

Power Consumption:

Sleep Mode: 5W with all relays non-energized

Typical Operational Mode:

14.2W - Run mode, LCD heater on,

6 relays energized

Battery Ride Through:

Withstands cranking ride-through down to 0 V for 50 ms (typical).

Current Sensing 5 Aac Current Sensing 1 Aac Current Sensing

Continuous Rating: 0.1 to 5.0 Aac 0.02 to 1.0 Aac

1 Second Rating: 10 Aac 2 Aac

Burden: 1 VA 1 VA

Voltage Sensing

Range: 12 to 576 V rms, line-to-line

Frequency Range: 10 to 72 Hz for 50/60 style and
10 to 480 Hz for 400 Hz style

Burden: 1 VA

1 Second Rating: 720 V rms

Contact Sensing

Contact sensing inputs include 1 emergency stop input and 16 programmable inputs. The emergency stop input accepts normally closed, dry contacts. All programmable inputs accept normally open, dry contacts.

Engine System Inputs

Fuel Level Sensing Resistance Range: 33 to 240 Ω nominal

Coolant Temperature Sensing Resistance Range:
62.6 to 637.5 Ω nominal

Oil Pressure Sensing Resistance Range: 34 to 240 Ω nom.

Engine Speed Sensing:

Magnetic Pickup

Voltage Range: 3 to 35 V peak (6 to 70 V peak-peak)

Frequency Range: 32 to 10,000 Hz

Generator Voltage Range: 12 to 576 V rms

Stated accuracies are subject to the accuracy of the senders used.

Output Contacts

Fuel Solenoid, Engine Crank, Pre-Start Relays Rating:

30 Adc at 28 Vdc-make, break, and carry

Programmable Relays (up to 12) Rating:

2 Adc at 30 Vdc-make, break, and carry

SPECIFICATIONS, continued

Metering

Generator Voltage (rms)

Metering Range: 0 to 576 Vac (direct measurement)
 577 to 99,999 Vac (through VT using VT ratio setting)
 Accuracy: $\pm 1.0\%$ of programmed rated voltage or ± 2 Vac

Generator Current (rms)

Generator current is measured at the secondary windings of user-supplied 1 A or 5 A CTs.
 Metering Range: 0 to 5,000 Aac
 CT Primary Range: 1-5,000 Aac, in primary increments of 1 Aac
 Accuracy: $\pm 1.0\%$ of programmed rated current or ± 2 Aac

Generator Frequency

Metering Range: 10 to 72 Hz (50/60 Hz)
 10 to 480 (400 Hz)
 Accuracy: $\pm 0.25\%$ or 0.05 Hz

Apparent Power

Indicates total kVA and individual line kVA (4-wire, line-to-neutral or 3-wire, line-to-line).
 Accuracy: $\pm 3\%$ or the full-scale indication or ± 2 kVA

Power Factor

Metering Range: 0.2 leading to 0.2 lagging
 Accuracy: ± 0.02

Real Power

Indicates total kW and individual line kW (4-wire, line-to-neutral or 3-wire line-to-line)
 Accuracy: $\pm 3\%$ of the full-scale indication or ± 2 kW

Oil Pressure

Metering Range: 0 to 145 psi or 0 to 1,000 kPa
 Accuracy: $\pm 3\%$ of actual indication or ± 2 psi or ± 12 kPa (subject to accuracy of sender)

Coolant Temperature

Metering Range: 32 to 410°F or 0 to 204°C
 Accuracy: $\pm 3\%$ or actual indication or $\pm 2^\circ$ (subject to accuracy of sender)

Fuel Level

Metering Range: 0 to 100%
 Accuracy: $\pm 2\%$ (subject to accuracy of sender)

Battery Voltage

Metering Range: 6 to 32 Vdc
 Accuracy: $\pm 3\%$ of actual indication or ± 0.2 Vdc

Engine RPM

Metering Range: 0 to 4,500 rpm
 Accuracy: $\pm 2\%$ of actual indication or ± 2 rpm

Engine Run Time

Engine run time is retained in nonvolatile memory.
 Metering Range: 0 to 99,999 h
 Update Interval: 6 min
 Accuracy: $\pm 1\%$ of actual indication or ± 12 min

Maintenance Timer

Maintenance timer indicates the time remaining until genset service is due. Value is retained in nonvolatile memory.
 Metering Range: 0 to 5,000 h
 Update Interval: 6 min
 Accuracy: $\pm 1\%$ or actual indication or ± 12 min

Generator Protection Functions

Reverse Power (32)

Pickup Range: -50 to 5%
 Activation Delay Range: 0 to 30 s

Loss of Excitation (40Q)

Pickup Range: -150 to 0%
 Activation Delay Range: 0 to 30 s

Overvoltage (59) and Undervoltage (27)

Pickup Range: 70 to 576 Vac
 Activation Delay Range: 0 to 30 s

Underfrequency (81U) and Overfrequency (81O)

Pickup Range: 45 to 66 Hz (50/60 Hz nominal)
 360 to 440 Hz (400 Hz nominal)
 Pickup Increment: 0.1 Hz (50/60 Hz nominal)
 0.1 Hz (400 Hz nominal)
 Activation Delay Range: 0 to 30 s

Overcurrent (51) (Optional)

Pickup Range: 0.18 to 1.18 Aac (1 A current sensing)
 0.9 to 7.75 Aac (5 A current sensing)

Time Dial Range: 0 to 30 s (fixed time curve)
 0 to 9.9 (inverse curve time multiplier)

Inverse Time Curves:

17 selectable Time Overcurrent Characteristic Curves

Phase Imbalance (47) (Optional)

Pickup Range: 5 to 100 Vac
 Pickup Increment: 1 Vac
 Activation Delay Range: 0 to 30 s
 Activation Delay Increment: 0.1 s

Environmental

Temperature

Operating: -40 to 70°C (-40 to 158°F)
 Storage: -40 to 85°C (-40 to 185°F)

Humidity:

IEC 68-2-38

Salt Fog:

ASTM B 17-73, IEC 68-2-11
 (tested while operational)

Ingress Protection: IEC IP54 for front panel

Shock: 15 G in 3 perpendicular planes

Vibration: 5 to 29 to 5 Hz: 1.5 G peak for 5 min.
 29 to 52 to 29 Hz: 0.036" DECS-A for 2.5 min.
 52 to 500 to 52 Hz: 5 G peak for 7.5 min.

Swept over the following ranges for 12 sweeps in each of three mutually perpendicular planes with each 15-minute sweep.

HALT (Highly Accelerated Life Testing)

Halt Testing is a method used by manufacturers concerned about high quality to prove that their products will provide the user with many years of reliable service. Halt testing subjects the device to extremes in temperature, shock, and vibration to simulate years of operation, but in a much shorter time span. Halt testing allows Basler to evaluate all possible design elements that will add to an increase in the life of this device. As an example of some of the extreme testing conditions, the DGC-2020 was subjected to Temperature Tests (tested over a temperature range of -100°C to +115°C), Vibration Tests (swept over a frequency of 5 to 50G at +20°C), and Temperature/Vibration Tests (tested at 40G over a temperature range of -80°C to +90°C). Please

SPECIFICATIONS, continued

note that the vibration and temperature extremes noted here are specific to HALT testing and do not reflect recommended operation level.

Agency Approvals

UL/CSA Approvals

"cURus" recognized to UL 508 R and CSA C22.2 No.14

NFPA Compliance

Complies with NFPA Standard 110, Standard for Emergency and Standby Power.

CE Compliance

This product complies with the requirements of the following EC Directives:

- Low Voltage Directive (LVD) - 73/23/EEC as amended by 93/68/EEC
- Electromagnetic Compatibility (EMC) - 89/336/EEC as amended by 92/31/EEC and 93/68/EEC
- EN 50178:1997 - Electronic Equipment for use in Power Installations
- EN 61000-6-4:2001 - Electromagnetic Compatibility (EMC), Generic Standards, Emission Standard for Industrial Environments
- EN 61000-6-2:2001 - Electromagnetic Compatibility (EMC), Generic Standards, Immunity for Industrial Environments

Physical

Weight: 2 kg (4.4 lb)

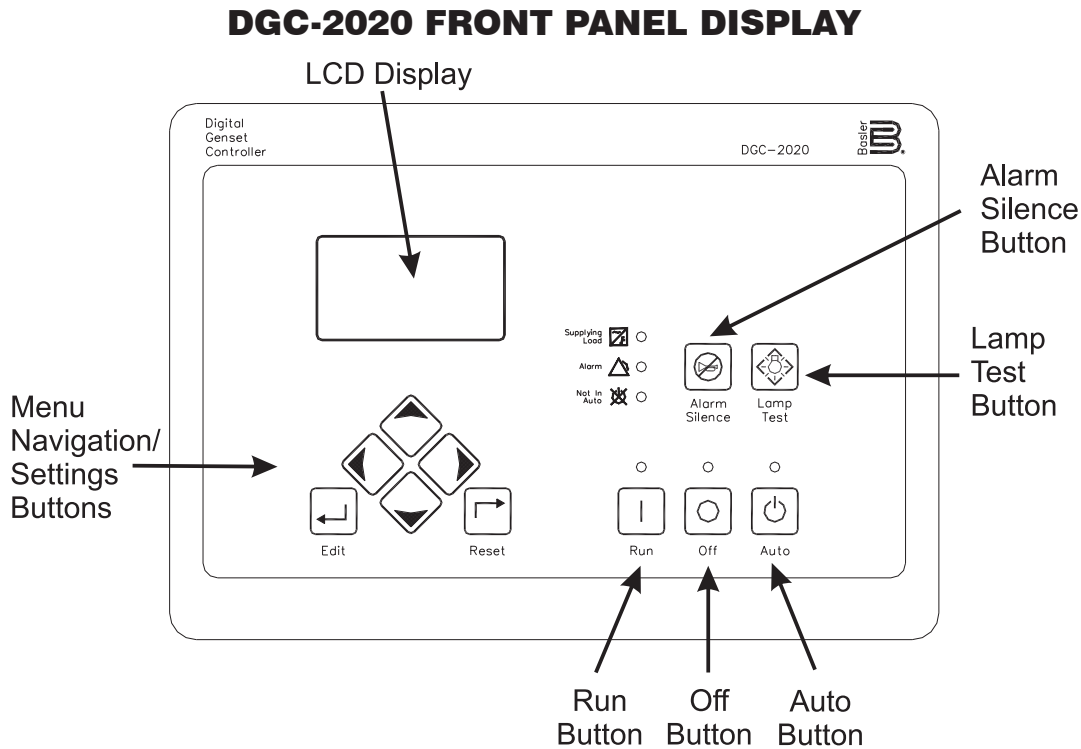

Figure 1 - Front Panel HMI (Human Machine Interface)

FRONT PANEL LED INDICATORS

- Run: Green - Indicates the DGC is in the RUN mode.
- Off: Red - Indicates the DC is in the OFF mode.
- Auto: Green - Indicates the unit is in the AUTO mode of operation.
- Supplying Load: Green - Indicates the system is supplying current to a connected load.
- Alarm: Red - Indicates an alarm situation by continuous illumination. Indicates a Pre-alarm by flashing.
- Not in Auto: Red - Indicates unit is not in the AUTO mode.

PACKAGING

DGC-2020 offers a complete system of environmental hardening. Its design utilizes advanced engineering and design techniques to allow it to operate in the harshest environments. The DGC-2020 uses encapsulated construction that has been successfully proven on hundreds of thousands of voltage regulators built by Basler. We have included an integrated gasket to seal the front panel to an IP54 rating, and we included a protective cover on the rear of the DGC-2020.

DIMENSIONS

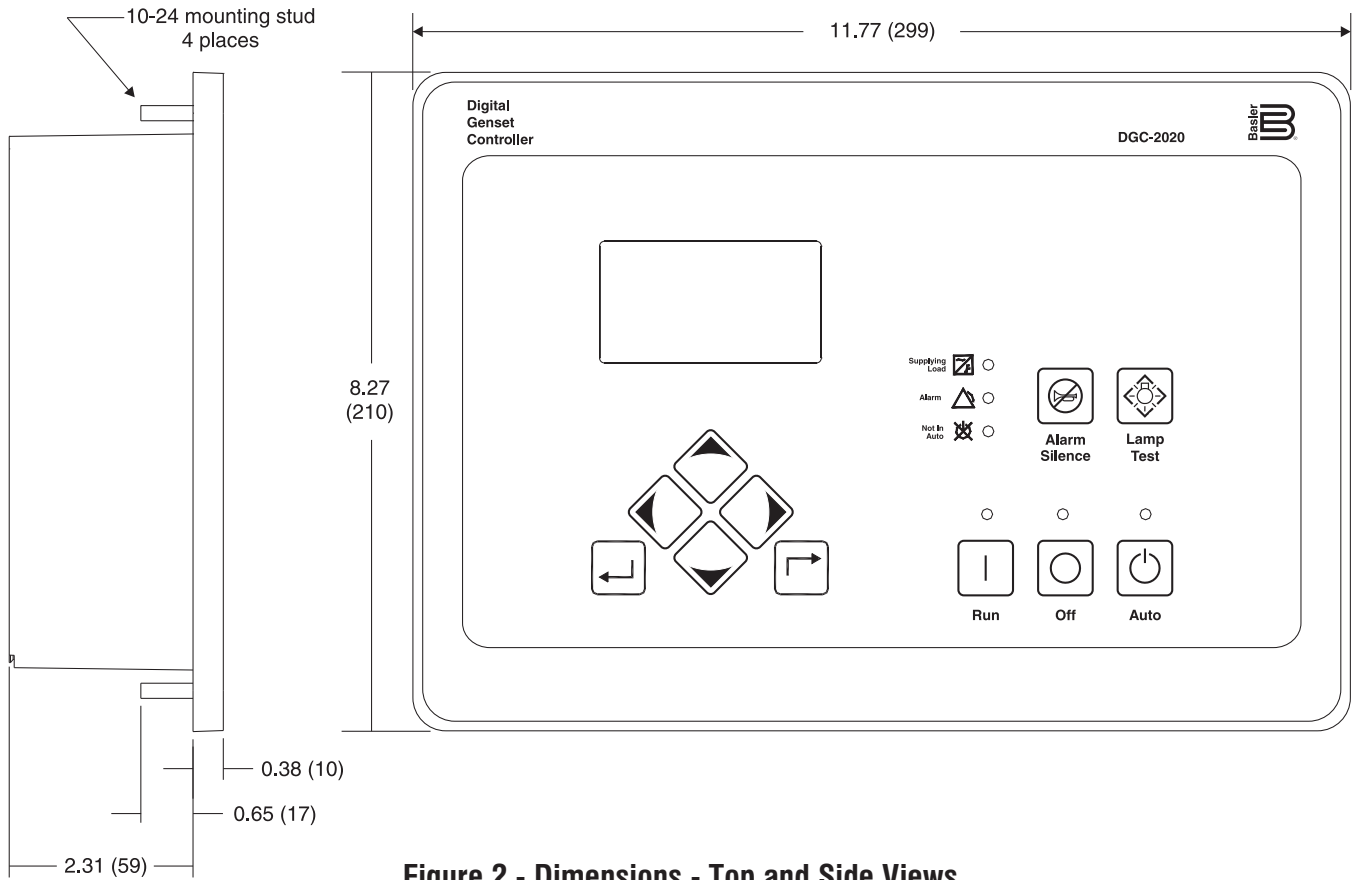

Figure 2 - Dimensions - Top and Side Views

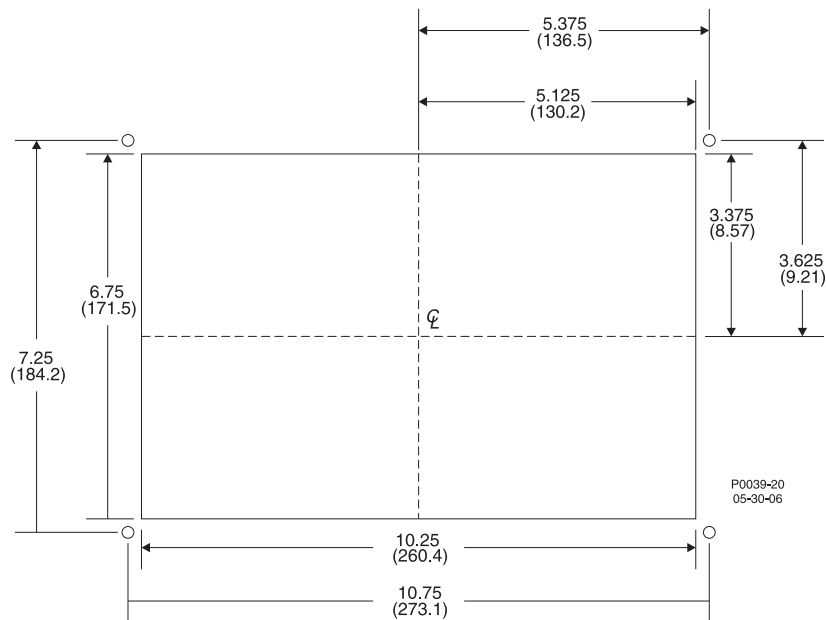

Figure 3 - Panel Cutting and Drilling Dimensions

- NOTES: 1. Dimensions in parentheses are in millimeters.
 2. All drawings and data subject to change without notice.

CONNECTIONS

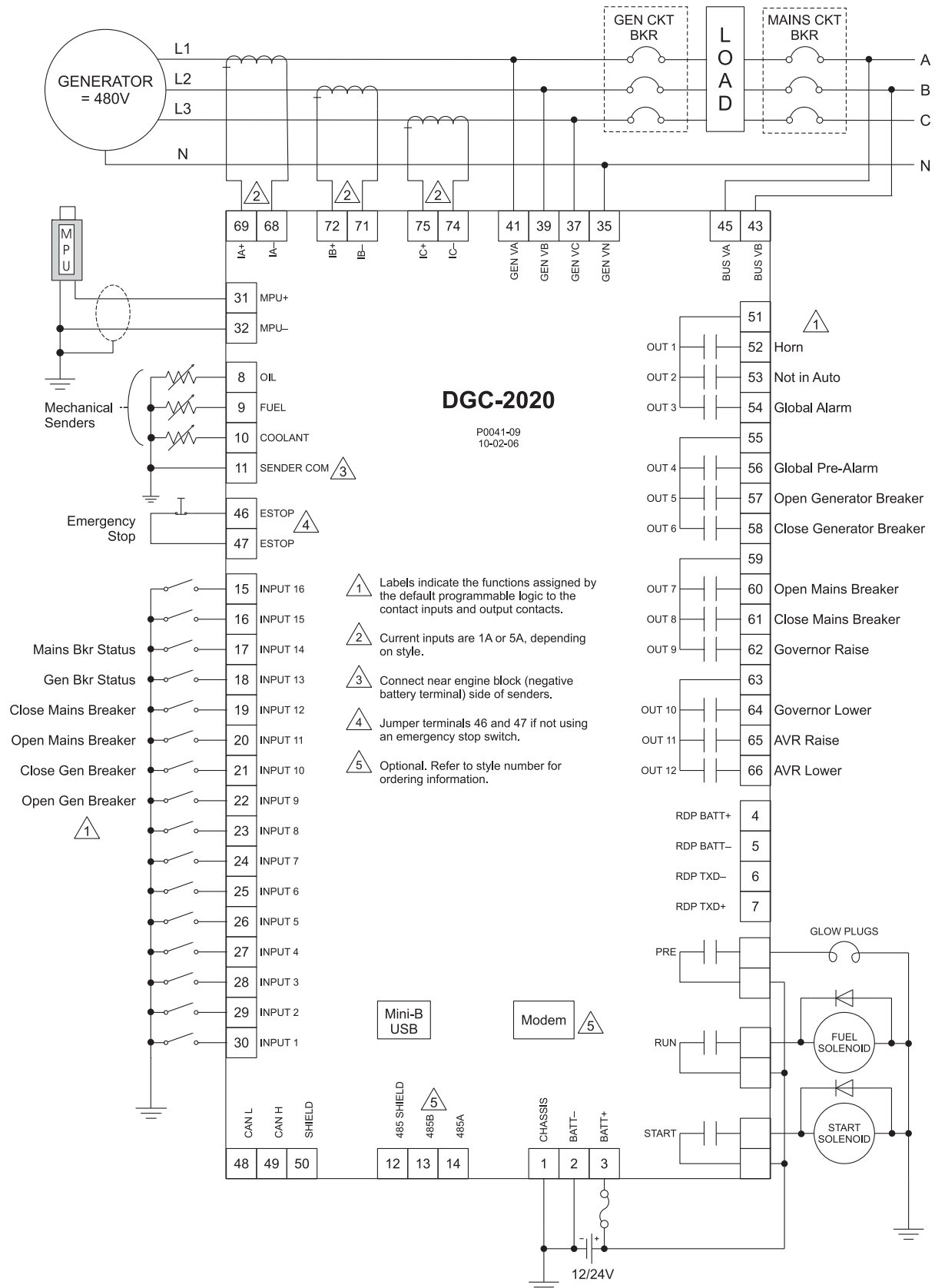

Figure 4 - DGC-2020 Typical Connections

ORDERING INFORMATION

OPTIONAL FEATURES

The DGC-2020 has been designed to provide maximum functionality at a minimum price. You only need to buy what you need. We have selected options to help maximize the value provided by the DGC-2020.

Additional Contact Outputs

For those applications where more output contacts are needed, the DGC-2020 can be adapted to include 8 additional 2 Adc rated dry contact outputs. These are real contacts and not the solid-state type that require additional external circuitry to properly operate. These contacts are fully programmable via the easy-to-use BESTCOMSPPlus PC software and can be assigned for numerous user-defined functions.

RS-485 Communications

When the RS-485 option is selected, the user can send and receive information from the DGC-2020 via the RS-485 communications port and Modbus protocol. This feature allows the DGC-2020 controlled genset to be fully integrated into the building management system. Please see the Instruction Manual for the Modbus register list.

Battery Backup for Real Time Clock

A ten-year (typical life) lithium battery is used to provide long-term maintenance of the real time clock setting. This battery is

serviceable by removing the rear cover. Please note that the settings, programming, and event records are saved in non-volatile memory and do not require battery backup.

Internal Modem

The DGC-2020 can provide long distance communications by including an internal modem. When the modem is selected, the user can access the DGC-2020 from virtually anywhere via a telephone line. The user can control and monitor the genset as if standing right next to it. The DGC-2020 can also dial out for pre-programmed circumstances to alert the user of selected conditions.

Enhanced Generator Protection

In addition to the standard generator protection (27, 32, 40Q, 59, 81O, 81U), the DGC-2020 also can be equipped with a more sophisticated generator protection system. This option provides an overcurrent element (51) with 17 selectable time current characteristic curves and a voltage phase balance protection function (47).

Auto-Synchronizer

When the DGC-2020 is configured with this option, the user can select between two types of autosynchronizer, phase lock or anticipatory style. In both methods, the DGC-2020 adjusts generator frequency and voltage to match that of the bus (mains) via contact outputs, then connects the generator to the bus by closing the connecting breaker.

STYLE CHART

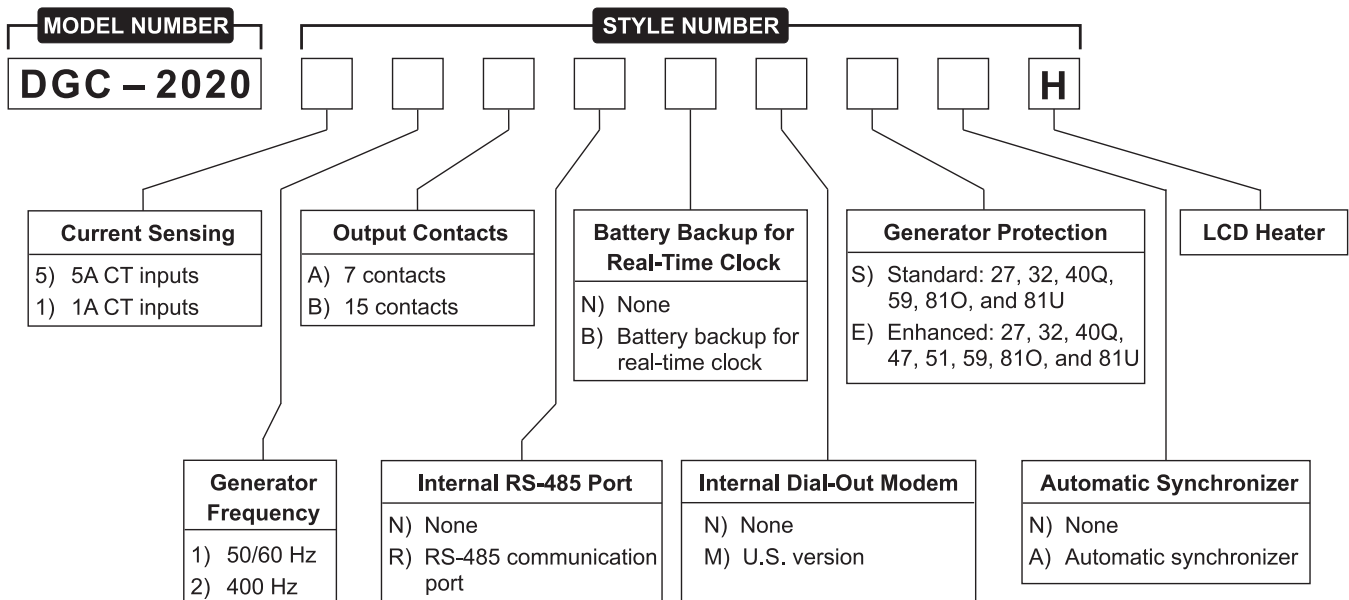

ENHANCEMENT ACCESSORIES FOR THE DGC-2020

Load Sharing Module for paralleled genset applications, LSM-2020

An easy to connect and use add-on module is available for the DGC-2020 to allow the DGC-2020 to control the kW load sharing of multiple generator sets. The LSM-2020 is remotely mounted and communicates to the DGC-2020 via J1939 Canbus communications. It has (3) three analog outputs. One output is connected to the voltage regulator and one to the speed governor. There is also one output connected to the load sharing lines. All of these outputs can be selected via BESTCOMS for 4-20 mA or ± 10 Vdc. No hardware changes are required. The analog outputs also can be scaled to adapt to the compatibility requirements of existing analog equipment.

This module also adds demand start/stop control and generator sequencing to the feature packed DGC-2020. The generator sequencing can be selected by priority number, generator size, service hours remaining, and balanced service hours.

This sequencing function is even smart enough to determine if all the connected controllers are in the same mode.

The LSM-2020 also adds Ethernet communications to the many communications features of the DGC-2020. It is IP addressable and allows all of the functionality of BESTCOMS to be utilized via Ethernet.

This module provides the installer with the flexibility to use the same model DGC-2020 genset controller for single unit (stand-alone power) applications and parallel genset applications. When the need occurs to parallel gensets, all that is required is to add this simple module. Pure flexibility is one of the benefits of the DGC-2020, and this add-on module enhances that. Drop it in, connect up and parallel gensets; nothing could be simpler!

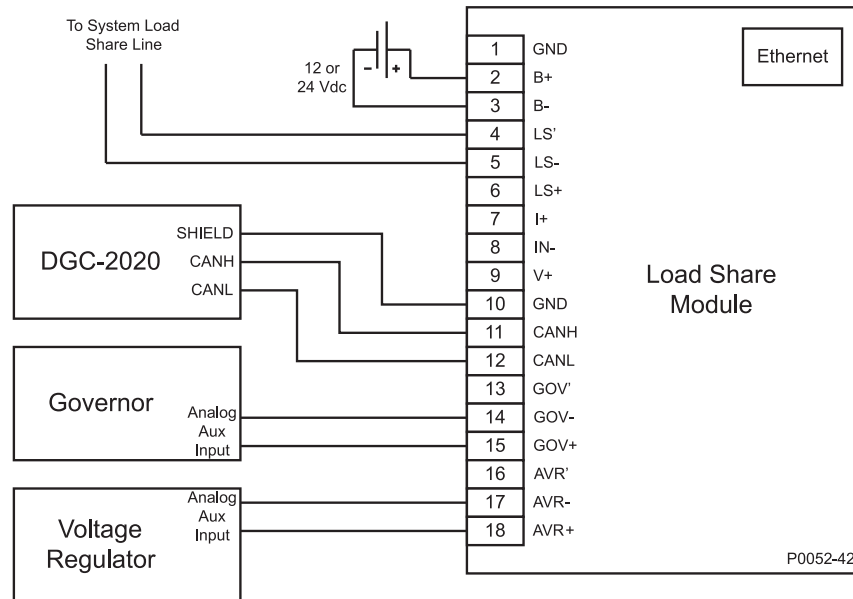

Figure 5 - Typical LSM-2020 Connections

ENHANCEMENT ACCESSORIES FOR THE DGC-2020 (Continued)

Load Sharing Module for paralleled genset applications, LSM-2020 (continued)

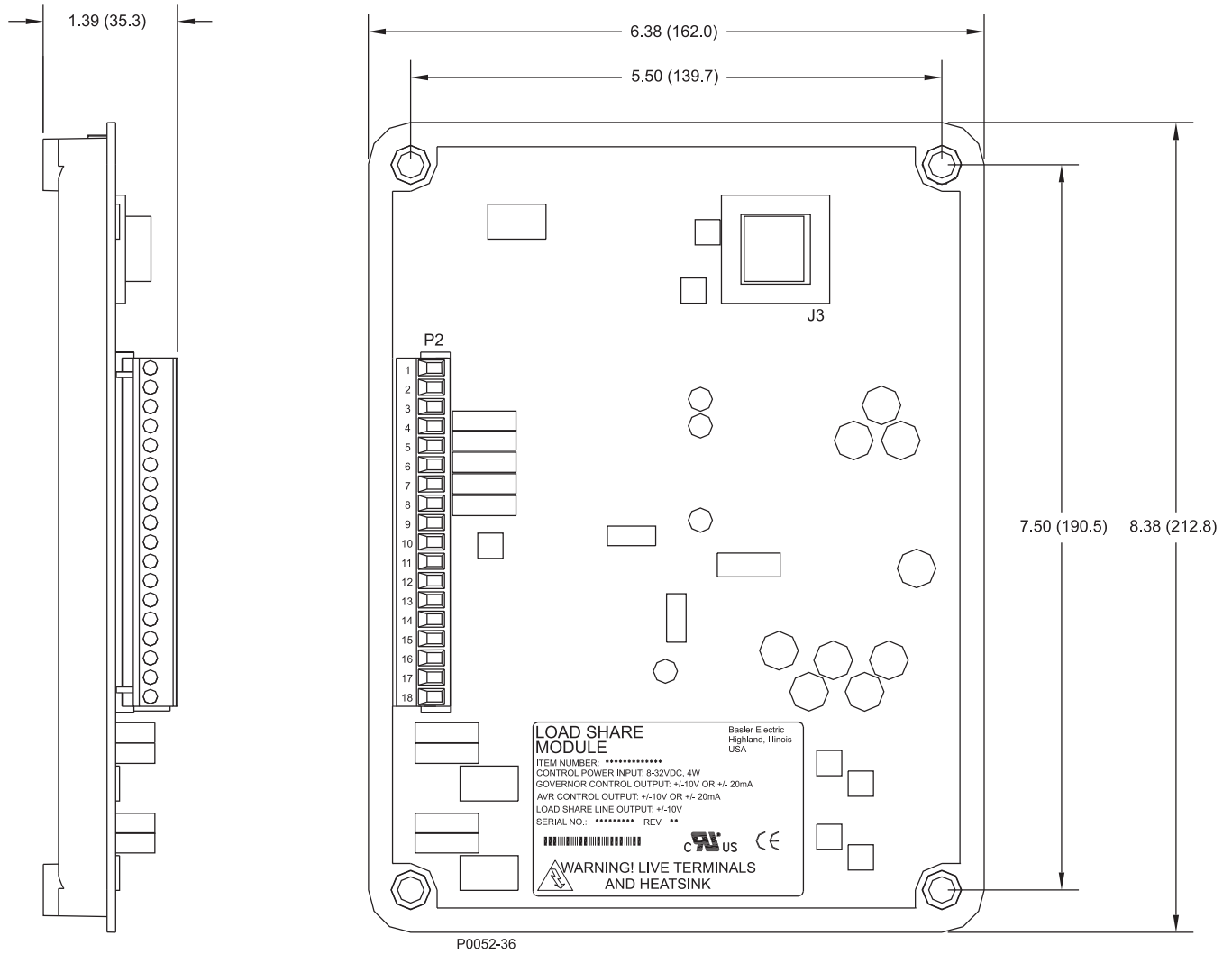

Figure 6 - LSM-2020 Overall Dimensions

ENHANCEMENT ACCESSORIES FOR THE DGC-2020 (Continued)

Contact Expansion Module for paralleled genset applications, CEM-2020

Basler Electric offers an add-on module to increase the already abundant contact input and contact output capability of the DGC-2020. This module adds 10 contact inputs and 24 form C contacts to the contact-rich DGC-2020 capability. This module communicates to the DGC-2020 via SAE J1939 Canbus and allows the user to program the functionality of these inputs and outputs in Basler's very powerful programmable logic program. The user can add labels for the inputs and outputs that appear in BESTCOMS, show up on the front panel, and in programmable logic. All the functionality can be assigned to these inputs and outputs as if they were an integrated part of the DGC-2020.

The output ratings of the form C contacts are:

- (12 contacts) 4 A @ 30 Vdc
- (12 contacts) 1 A @ 30 Vdc

The 1 A rated contacts are gold contacts for low current circuits.

This module provides the user with the flexibility to use the same model DGC-2020 genset controller for simple applications or more complicated applications that require contact functionality or duplication of contacts for remote annunciation. Pure flexibility is one of the benefits of the DGC-2020, and this add-on module enhances that benefit every further. Drop it in, connect it up, and you have added 10 more contact inputs and 24 more contact outputs. Nothing could be simpler.

For installation instructions, see Instruction Manual Publication 9400200990.

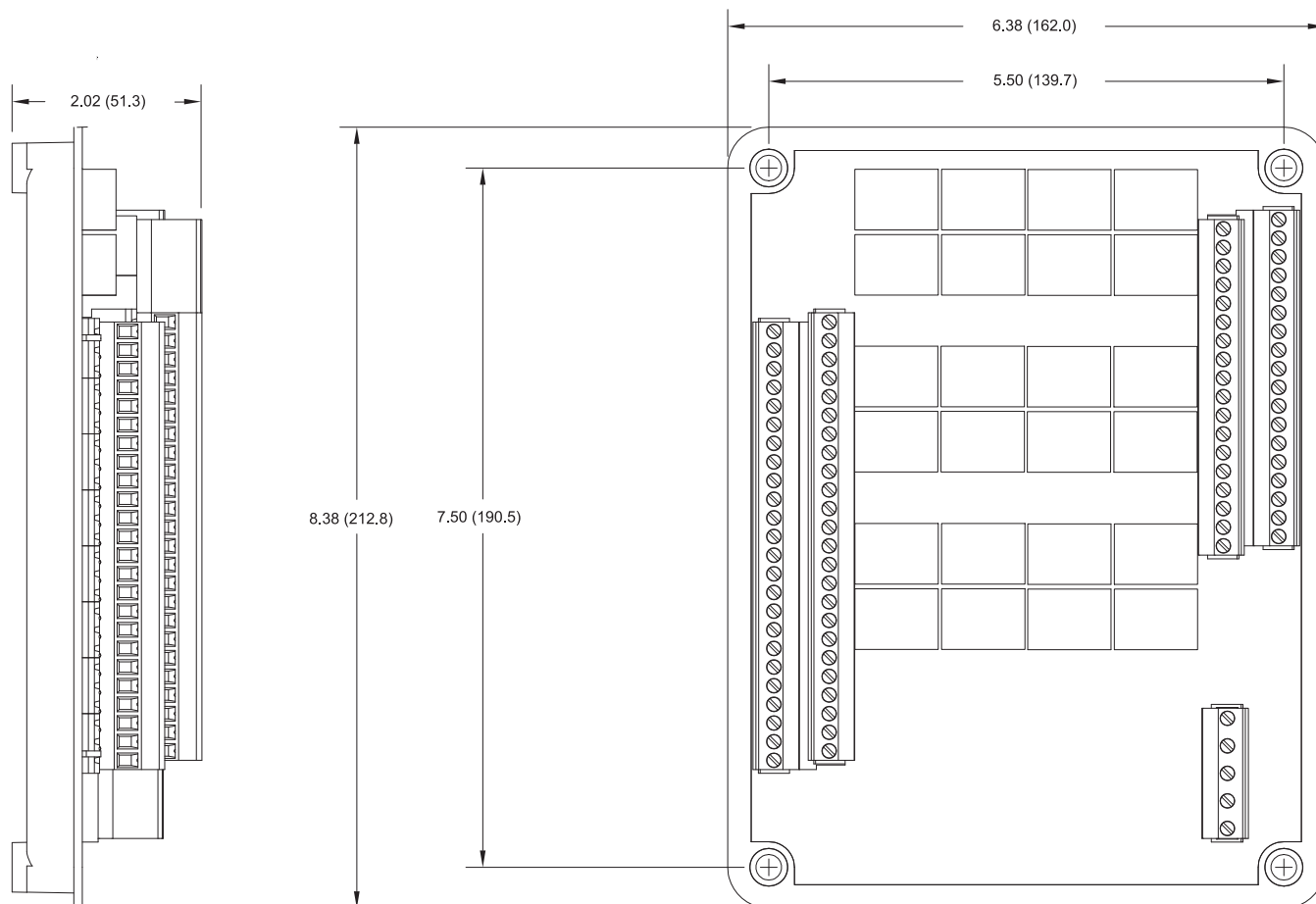

Figure 7 - CEM-2020 Overall Dimensions

ENHANCEMENT ACCESSORIES FOR THE DGC-2020 (Continued)

Analog Expansion Module for applications requiring analog inputs/outputs and temperature monitoring, AEM-2020

Basler's optional AEM-2020 module provides eight remote analog inputs, eight remote RTD inputs, two remote thermocouple inputs, and four remote analog outputs to the DGC-2020. The AEM-2020 communicates with the DGC-2020 through a CANbus interface.

The eight analog inputs are user-selectable for 4 to 20 mA or 0 to 10 Vdc. Each analog input has under/over thresholds that you can configure as status only, alarm, or pre-alarm.

Each of these inputs can be selected and used in our powerful programmable logic software.

For temperature measurement, the AEM provides for eight RTD inputs that can be configured for 10 or 100 Ohm RTDs. It also has two inputs for K-type thermocouples. Each of these ten temperature measurement inputs can be configured with high or low temperature thresholds. Each of these inputs can be selected and used in our powerful programmable logic software.

The analog outputs are user-selectable for 4 to 20 mA or 0 to 10 Vdc. These outputs are intended to drive external analog meters and can be configured for indication of a wide range of parameters, including oil pressure, fuel level, generator voltage, and bus voltage.

For installation instructions, see Instruction Manual Publication 9400200990.

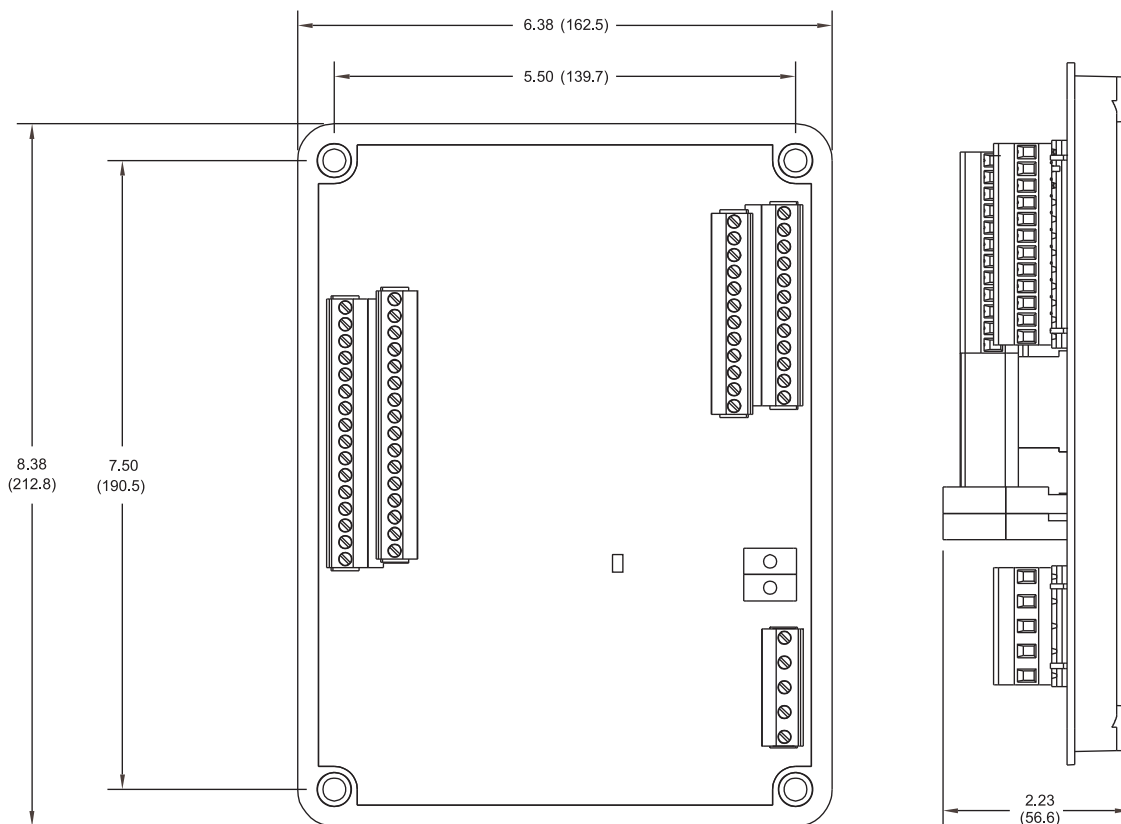

Figure 8 - AEM-2020 Overall Dimensions



ISO 9001-2000
Highland, IL USA Taylor, TX USA
Wasselonne, France Suzhou, China

B Basler Electric



PA.E. Les Pins, 67319 Wasselonne Cedex FRANCE
Tel +33 3.88.87.1010 Fax +33 3.88.87.0808
e-mail: beifrance@basler.com

Route 143, Box 269, Highland, Illinois U.S.A. 62249
Tel +1 618.654.2341 Fax +1 618.654.2351
e-mail: info@basler.com

No. 1300 North Zhongshan Road, Wujiang Economic Development Zone
Suzhou, Jiangsu Province - P.R. China 215200
Tel +86(0)512 6346 1730 Fax +86(0)512 6346 1760
e-mail: beichina@basler.com

www.basler.com